



SHINGLEBACK PRO

Rack Assembly Instruction and Install Booklet





We'd like to take this opportunity to welcome you to the Shingleback Off Road community.

You are amongst a growing number of satisfied customers who are enjoying the great outdoors and transporting their bikes in style.

We know you're excited especially when you're getting ready to take your bike out to your favourite trails... but before you do, you need to correctly assemble your vertical bike rack.

Activate your Warranty

To ensure we have the latest contact information please register your rack online to ensure you are kept up to date with our latest developments and any safety related advice we would like to share with you.

Once registered your rack is covered by our 10 year guarantee. Visit shinglebackoffroad.com.au/register to learn more or scan the QR code at right.

If you have purchased your rack from one of our stockists, please ensure you retain your receipt for proof of purchase.

10 YEAR
GUARANTEE



Caring for your rack

To maintain the look of your new Shingleback rack and to keep it operating as it should, here are some quick tips to keep you happy on the trails.

MAINTENANCE

Before each outing, check these items on your Shingleback rack.

- The rack is firmly in towbar and the hitch pin is in place.
- Check the anti rattle clamp is firmly secured by checking the U-bolt nuts have been done up tightly. This part does wear over time and if you need replacement parts for this attachment please visit our website to purchase.
- All nuts and bolts are tightened to the correction specifications outlined in this instructions.
- Inspect speed lock pin for proper function (refer page 13 for details).
- The Anti Rattle Bolt (ARB) is supplied with anti seize thread paste applied to the thread. It is important to re-apply every few months or as required. Grease can also be used.

CLEANING

- After each adventure or outing, Shingleback Off Road recommends cleaning the rack with a soft cloth and warm soapy water to wash off any road grime or dirt.
- Rinse off with cold water.

Now the fun begins!

To ensure your rack performs as it should, please carefully follow the assembly instructions for the rack you purchased. We highly recommend watching the assembly video before you start.

Scan the QR code at right or visit:
shinglebackoffroad.com.au/shingleback-pro-instructions





STEP 1: CHECK THE PARTS AND GATHER YOUR TOOLS

Got a problem with your parts? Visit shinglebackoffroad.com.au/product-support

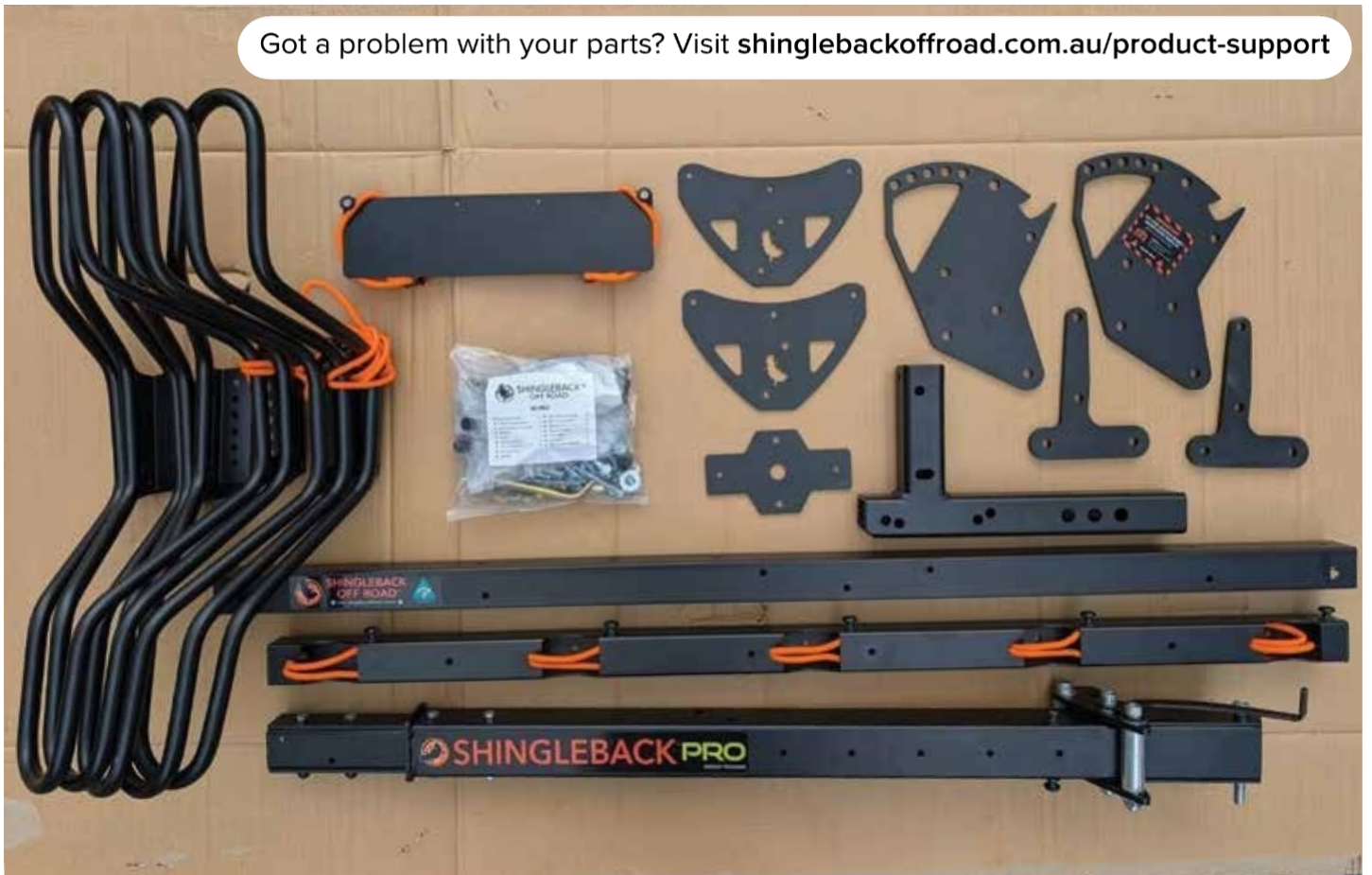

Anti-rattle Clamp (ARC)





STEP 2. THE TOW BAR TUBE

TIP: *Build your rack on your car for a solid base to work from.*

1. If your hitch receiver has a plastic surround please remove to ensure a secure fit of the Anti-rattle Clamp (ARC).
2. Insert the tow bar tube deep into your hitch and observe which hitch pin hole suits your vehicle, then remove.
3. Anti Rattle Bolt (ARB) - insert the magnetic nut into the tow bar tube and slide in until it lines up with the hitch pin hole you just identified.
4. Assemble the ARC and slide onto the tow bar tube, let it hang loose for now.
5. Now insert the tow bar tube into your car's hitch, line up the hitch pin hole, and secure it with the ARB. Be sure to start the thread properly, then do up very tight to clamp the tow bar tube sideways into your car's hitch.
Always start the thread by hand before using a mechanical tool to prevent cross-threading the bolt.
6. Now position the ARC and tighten, alternate each side until tight.

NOTE: *200/300 series Land Cruisers require a custom ARC, sold separately.*





STEP 3. PIVOT BOX

1. Fit the pivot plates. Note there are two settings, Standard setting has the rack slightly tilted towards the car, Back setting tilts the rack slightly back.
2. Fit the Speed Lock Pin (SLP) tab washer to one of the big bolts, and insert into the top mount hole of the pivot plate with the sticker, and fit one of the spacers to the inside of the pivot plate.
3. Fit this pivot plate with spacer assembly to the tow bar tube, the SLP bolt is the top mount bolt hole of the tow bar tube, and is also used to pivot the pivot plates between the two tilt settings.
4. Standard tilt setting is recommended and works with most vehicles, fit the three other mounting bolts with a washer under the head. The tilt setting can be changed when the build is finished if needed.
5. Fit the other spacer and pivot plate, washer and nut for each bolt. For now just nip up the low bolt closest to your car to help with the next step.





STEP 4. CENTRE POST WITH HEIGHT ADJUSTMENT

1. Fit the two springs
2. Fit the centre post in the fully tilted down position, be careful to line up and pass the pivot bolt through the two plastic spacers.
3. Lift the centre post into the upright travel position with the latch fully engaged.
4. Fit the SLP.
5. Tighten the pivot box bolts, all tight except for the pivot bolt (tight then back ¼ turn) .
6. Fit the Bent Pin and R clip in one of the positions to limit tilt back.

NOTE: *There's a spare big bolt, washers and a nut. This can be used in place of the Bent Pin to limit tilt back (but must be left loose to avoid binding the rack as it tilts) or if tilting back easily isn't needed and a 100% solid fit is needed, the bolt can be used in place of the SLP to clamp the centre post tight.*



HEIGHT ADJUSTMENT

1. There is 280mm of height adjustment in the centre post
2. The centre post is loosely assembled in the Default height setting which suits most vehicles. If this suits your needs simply tighten the two bolts to clamp the telescopic top section in place, fit two plastic nut caps.
3. To change height settings simply remove the two bolts and slide the top section down or up from the Default setting.

IMPORTANT: *Do not exceed the Maximum height setting, identified when there are 4 adjustment holes visible in the telescopic section.*



The max. height setting is when 4 adjustment holes are visible



STEP 5. TOP BAR PLATES

- Fit the top bar plates using two of the 5 bolts as shown with washer & nut on the back.



STEP 6. TOP BAR

- Fit the top bar with the sticker and Shingleback cut outs facing away from the vehicle.
- Fit just the 2 outer small mounting bolts for now, washer and nut on the car side of the rack.

NOTE: *Don't stress, the Top bar is designed to be off centre, this is to ensure the bikes are centred to the vehicle.*



STEP 7. CRADLES *MORE PHOTOS OVERLEAF*

IMPORTANT: *Install cradles so bike wheel tilts to the right.*

IMPORTANT: *Don't over-tighten the cradle mount bolts to prevent crushing the top bar.*

- Fit the cradles, start left to right, use the "DEFAULT PATTERN" as pictured overleaf.
- Fit the crush tube to the end cradle mount holes only.
- Dangle bolts with a washer under the head through mount holes and lower onto the top bar.
- Use a washer under the head of the bolt and a washer underneath the top bar with the nut.
- When up to fastening the cradle mount bolt that is at the centrepole, remove the right hand top bar plate bolt and carefully allow the top bar to tilt sideways to give access.
- Re-fit the top bar plate bolts (all three this time) and tighten all 5 top bar plate bolts.
- Fit the remaining cradles, with a crush tube and end cap in the end.
- Fit nut caps on the underside of the top bar.



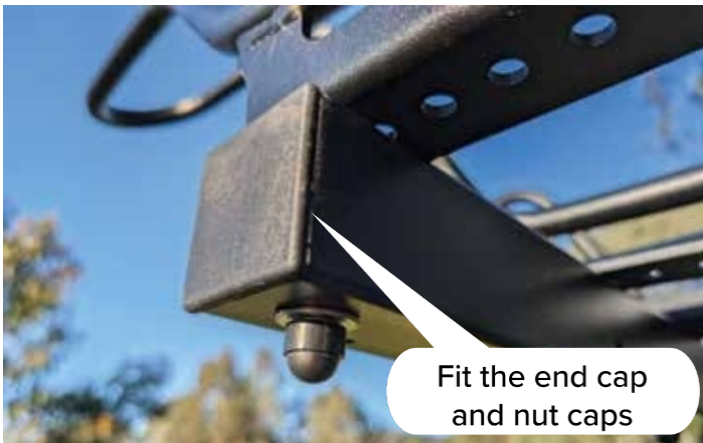
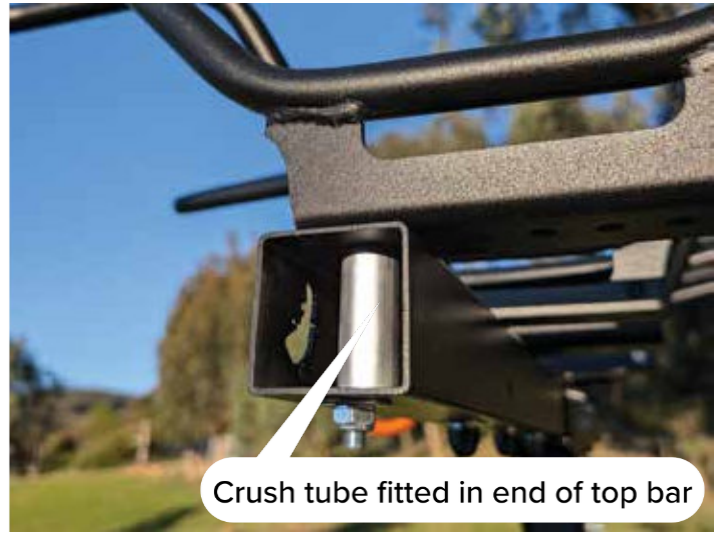

Examples of the multi-adjustable cradle movements:

Rotational adjustment →

Back & forward adjustment →

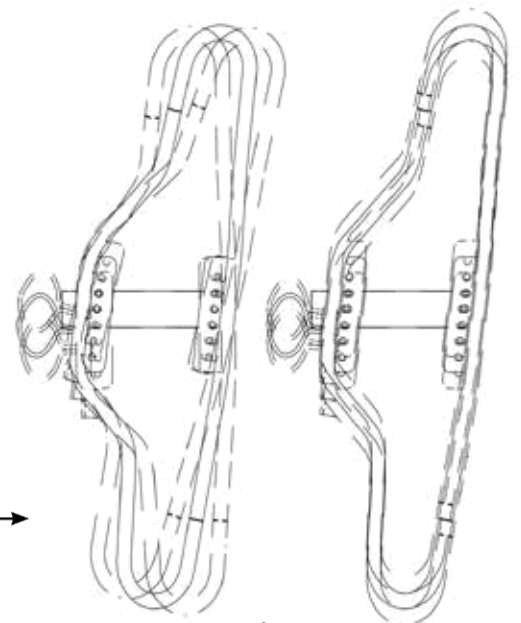



4 BIKE CRADLE DEFAULT PATTERN

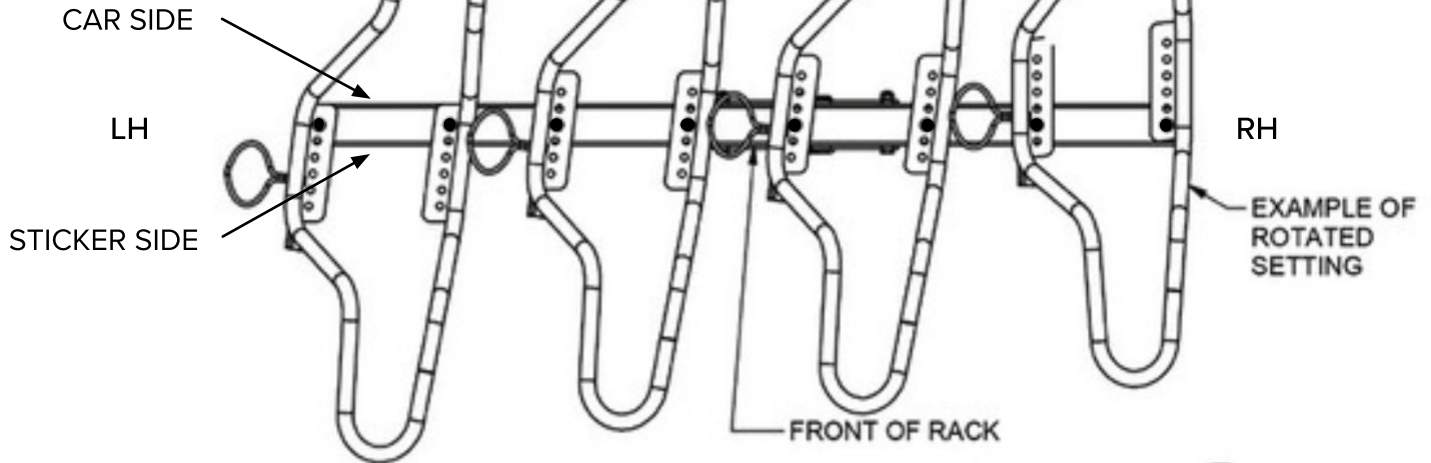

5 BIKE CRADLE DEFAULT PATTERN

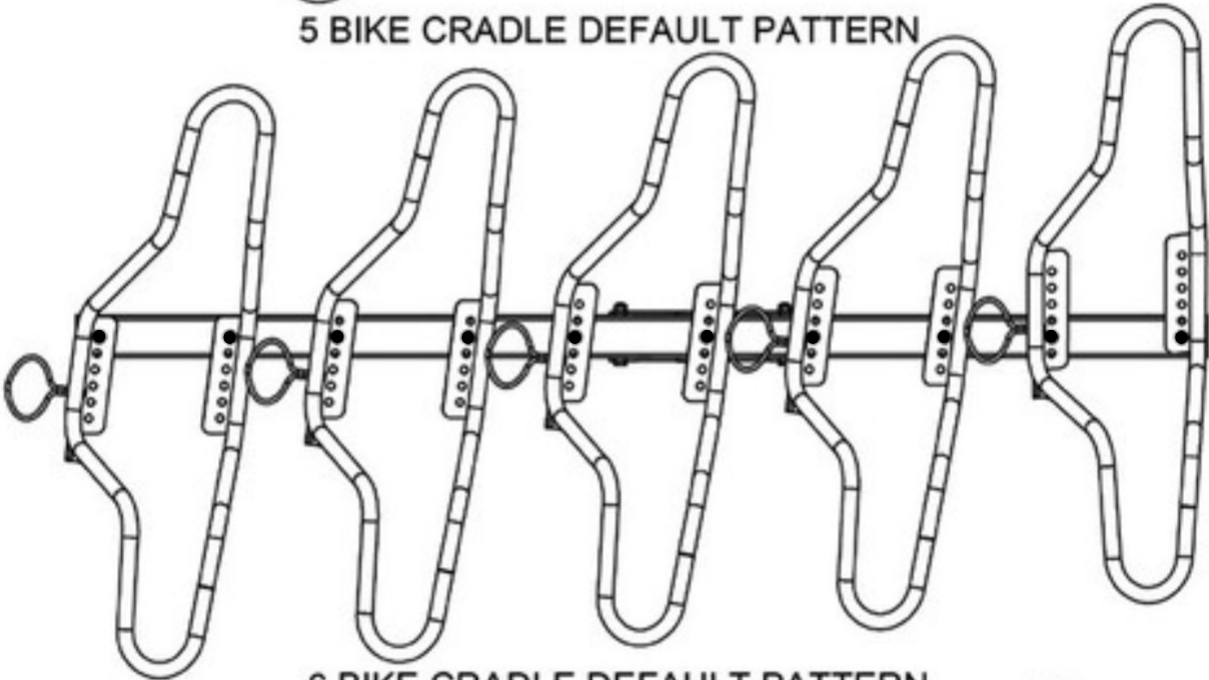

6 BIKE CRADLE DEFAULT PATTERN

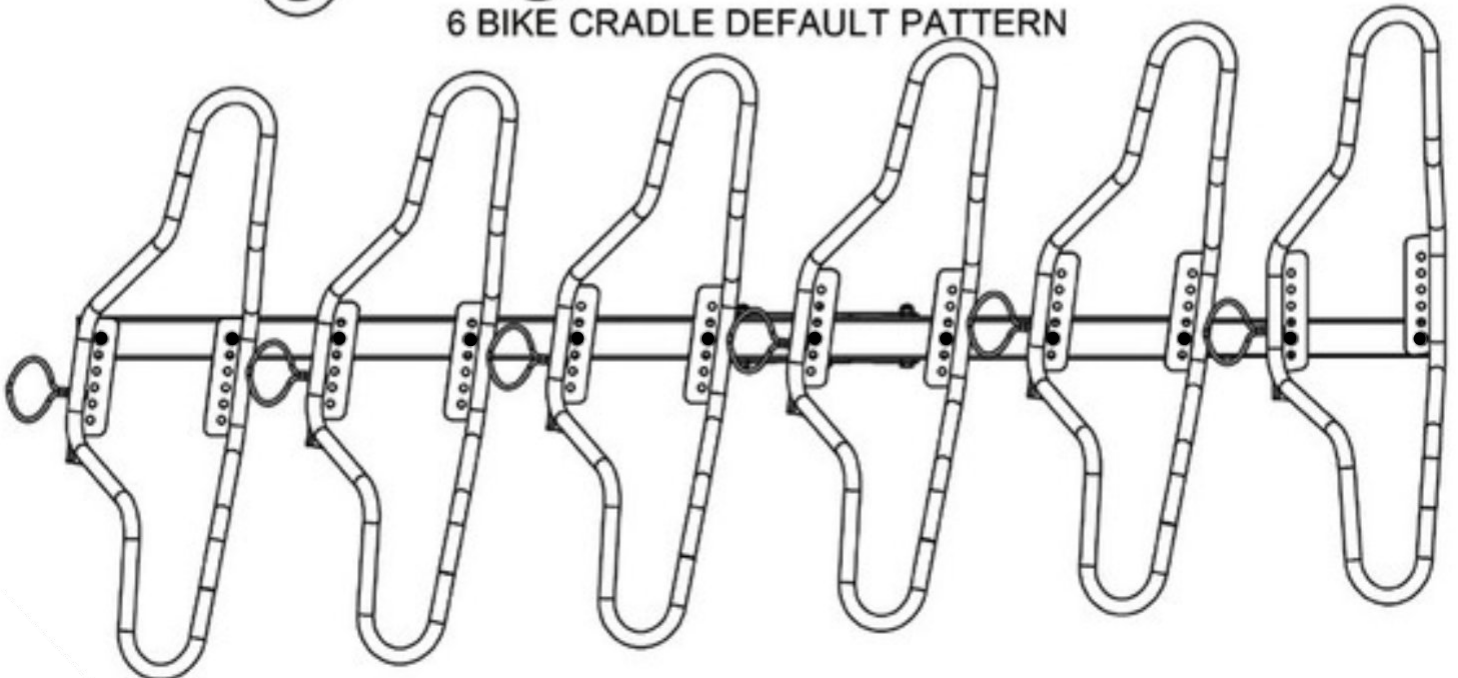



STEP 8. BOTTOM BAR PLATE AND BOTTOM BAR

- Use the two longer small bolts (in the small plastic bag) to fit the bottom bar plate to the centre post. Use a height position that is about the centre of your bike's rear wheel.
- Fit the bottom bar, ensure the buttons are on top. For the 6B, use the longer bottom bar plate and extra bolts provided.

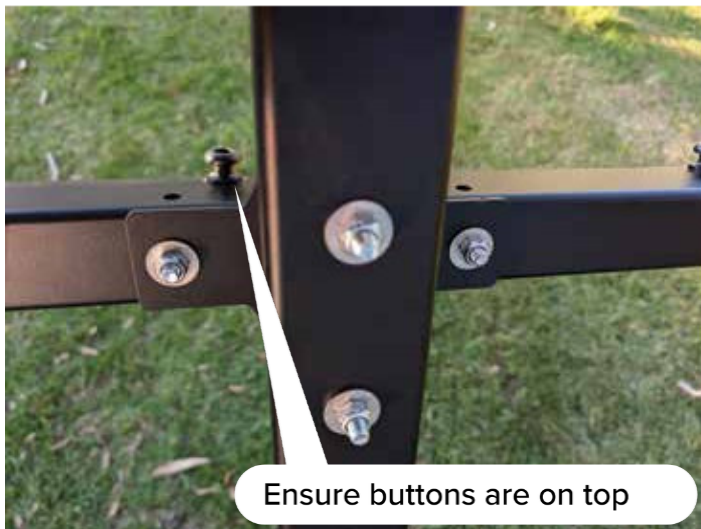
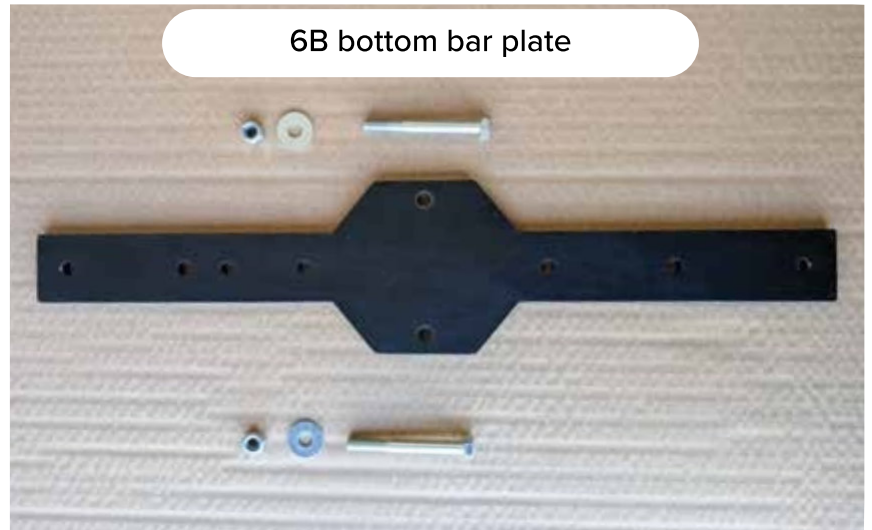

FITTING THE 6B BOTTOM BAR PLATE



STEP 9. NUMBERPLATE BOARD

- Attach your bike rack number plate to the number plate board with cable ties or bolts (not included).
- Fit the numberplate board to the bottom bar as shown.
- When bikes are loaded the numberplate board can be attached to the rear wheels.
- **IMPORTANT:** contact state/ territory road authority to order your auxiliary plate.



IMPORTANT: ensure your tail light and indicators are visible. A light board may be required, available separately.



Operating Instructions

TILTING BACK: TRAVEL TO LOAD POSITION

- Make sure the Tilt Limit Bolt is in the desired position to limit tilt back
- Remove the Speed Lock Pin
- Brace yourself, then activate the foot latch to release the rack while controlling the weight of the rack and any bikes as it lowers, **NEVER DROP**, if the rack is loaded two people may be needed.

LOADING BIKES

- Rule of thumb is to load from left to right, biggest/longest travel bike to smallest. However, because of the multi-adjustable cradles it's possible to set your rack up so you have a big bike in the middle and smaller bikes on each side. This not only looks more balanced but it also reduces the risk of the long bike contacting the ground.
- **E bikes:** Always load e bikes in the centre of the rack, don't exceed the rack or your vehicle's/ tow hitch weight ratings.
- **Roll in loading:** When the rack is tilted back into the load position, it's possible to roll the bikes in without the need to lift the bikes over your head. An easy way to get the bike onto its back wheel is to simply apply the rear brake and walk backwards. Now wheel the bike towards the cradle on about a 30 deg angle, aiming for the middle of the cradle end. Push on the handlebars as you guide it in. Fasten both the top and bottom bungees.

TIP: Use your knee under the bike seat for an extra boost as you push the bike into the cradle.

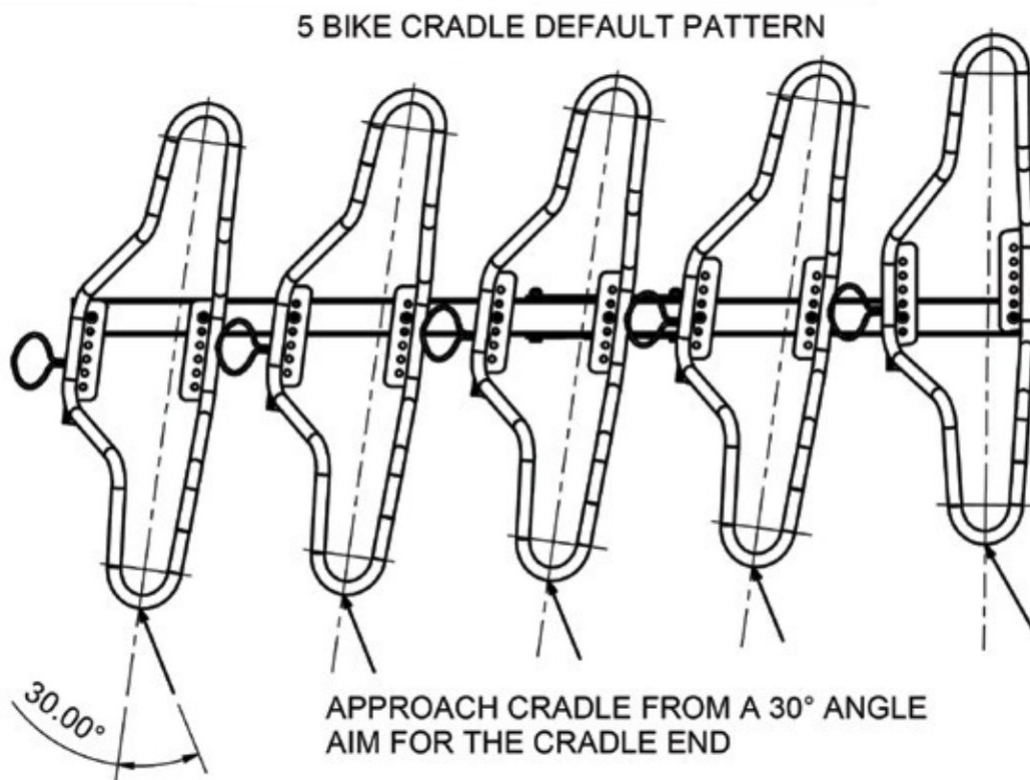

STANDING BACK UP: LOAD TO TRAVEL POSITION

- Push the rack up until it auto latches in the upright or travel position, two or more people may be needed
- Fit the Speed Lock Pin.



Speed Lock Pin

The Shingleback Speed Lock Pin (SLP) is used as a secondary safety factor when using a Shingleback vertical bike rack. Unlike the traditional pin with R clip there is no need to fiddle around trying to insert the clip while awkwardly reaching around all the bikes, the SLP is a super easy one hand operation solution accessed from the one side and it also has the bonus of being attached by a steel cable lanyard to ensure it won't be misplaced or lost.

Under normal conditions there is no load on the SLP, but in the unlikely event of the main latch failing the SLP will securely hold the rack in place giving you peace of mind that you and your bikes are safe.

INSPECTION BEFORE EACH USE

Visually and by touch, inspect the Speed lock Pin for cracks, distortion, corrosion, scratches or gouges, sharp edges or rough areas. Check the ball lock retention mechanism for proper function. Remove from service if there is any doubt about its safety or serviceability.

INSTRUCTIONS

The two locking balls are disengaged by pressing the button on the end, the SLP can now be fitted through the pivot box and centre post of your rack. Always make sure the button returns fully when released.

If the button doesn't return fully or becomes stuck in, DO NOT USE THE RACK and replace SLP.

MAINTENANCE

Do not be tempted to use WD40, chain lube, oil or any other wet lube as these all attract dust and can cause the mechanism to clog and jam.

The SLP is made from quality marine grade stainless steel and is largely maintenance free, however dry synthetic lubricants such as those used by locksmiths can be used if needed.

If the button becomes sticky or stuck in, this is usually because of dust entering the mechanism. This can be flushed out by submerging the SLP in a bucket of clean water, sloshing around and actuating the button many times to work the dust out. Keep going until the function has returned to normal, otherwise remove from service and order a new SLP from our website.



Fit SLP under the head of the pivot box bolt.



Scan the QR code for further information and to view the installation video.



IMPORTANT!

Always fit the Speed Lock Pin as shown before travelling.
NOTE: the type of safety pin may vary depending on supply.

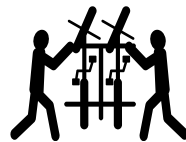

Always brace yourself and control tilting.



NEVER DROP



MAX. WEIGHT
PER CRADLE  **MAX
35KG**

MAX. WEIGHT
RACK + LOAD*  **60%**

MAX. CARRYING
CAPACITY**  **MAX
105KG**

* The total weight of the rack and load must not exceed 60% of the vehicle's tow hitch tow ball rating. ** Regardless of your vehicle's tow hitch download rating, the maximum carrying capacity of the rack is 105kg.

IMPORTANT: A swingarm reduces your bike rack's load rating. Dirt roads can reduce load ratings. Shingleback Off Road recommends that you brace the rack to your vehicle with ratchet straps if driving on uneven surfaces. See shinglebackoffroad.com.au for more details.



Make the most of your bike rack with our range of genuine Shingleback Off Road parts and accessories.

UTILITY HOOK



PEDAL STRAP



BMX INSERT



ROADIE CRADLE TILT BRACKET



THE EXTENDER

ROADIE INSERT



SKI CLAMP



SWING ARM



LIGHT BOARD



FLOOR STAND



DOLLY STAND



ANTI RATTLE BOLT



OFF SET TOW BAR TUBES



RANGE OF DIFFERENT LENGTH TOW BAR TUBES





Our 10 Year Guarantee. We love our work!

We're so confident in the workmanship of our Shingleback Racks that we're prepared to offer customers a 10 Year Guarantee.

The workmanship guarantee covers:

- Build quality
- Welding

If you experience an issue with your rack, please contact us directly and we will work with you to find a solution.

Excluded from guarantee:

- Damage from misuse of the product, or use against the advice of Shingleback Off Road
- Damage from accidents
- Bungee cord loops and buttons (these will last a long time but they have a limited lifespan)
- Powdercoating (while it is an industrial scratch resistant powdercoat we can't guarantee against it being worn through)
- Anti rattle clamp (Over extended periods of usage this part should be replaced as the U-bolt wears over time – purchase of this part is available on our website)
- Rust
- Stickers

For more information visit shinglebackoffroad.com.au/warranty



Shingleback Rack Structural Warranty Terms And Conditions

Please read the following document carefully.

This document describes what is included in the New Product Warranty, and what is not covered by the New Product Warranty. By purchasing from us, you agree to the terms and conditions of this Warranty.

1. General

1.1. Shingleback Off Road Pty Ltd (ACN 633 831 393) ('Shingleback') gives this New Product Warranty ('Warranty') in relation to its vertical bike rack, dolly stand, swing arm and floor stand products ('Product(s)').

1.2. Product(s) purchased from Shingleback are warranted by us to be free from defects for the duration of this Warranty period subject to these terms and conditions ('Terms').

1.3. The benefits provided by this Warranty are in addition to other rights and remedies available to you under the Australian Consumer Law ('ACL').

1.4. Any reference herein to "we", "our", or "us" means Shingleback. Any reference to "you" or "your" means you, as the original consumer purchaser ('Customer').

2. Limited Warranty

2.1. Shingleback warrants to the Customer that the Product(s) supplied by Shingleback will be free from manufacturing defects, and under normal use when reasonable care and maintenance is applied, within the Warranty periods set out in these Terms.

2.2. This Warranty is limited to the first purchaser and it is not transferable on the sale or other disposition of the Product(s).

2.3. The liability of Shingleback under this Warranty is limited to the repair or replacement the Product(s) or defective part of the Product(s) or the cost of such repair or replacement in the discretion of Shingleback.

2.4. To the fullest extent permissible at law, Shingleback's liability for incidental and consequential damages resulting from the operation, maintenance, or use of your Product(s) is expressly excluded.

3. Warranty Coverage and Warranty Period

3.1 Items manufactured by Shingleback that comprise the structural components of the Product(s) are covered by this Warranty for a period of ten (10) years from delivery of the product(s), subject to, but not limited to, the following specifications and/or exceptions:

(a) the welded and steel structure of Product(s) are covered by a ten (10) Year warranty;

(b) all other components and parts of the Product(s), excluding the items in 3.1(a), are covered by a three (3) month warranty;

(c) Warranty for Product(s) being used commercially or 'off-road' is limited to a two (2) Year Warranty;

(e) Warranty for Product(s) used in a hire application is limited to a one (1) year warranty.

3.2. Unless otherwise specified, the warranties in this Warranty commence on the day you receive the new Shingleback Product(s).

4. How you can make a claim

4.1. Any claim in relation to a Warranty should be referred to an authorised Shingleback employee. All warranty defects must be reported to an authorised Shingleback employee as soon as possible and within a reasonable timeframe.

(a) In order to make a claim under this Warranty, a consumer must, at its own cost present the Product(s) to an authorised Shingleback dealer; and collect the Product(s) at their expense once notified that it is ready for collection. If an authorised dealer is not reasonably available, Shingleback may at its discretion allow the Product(s) to be presented at an alternative location.

A list of all authorised Shingleback Stockists and their location and contact details may be found at Shinglebackoffroad.com.au/stockists

(b) To make a Warranty claim during the warranty period, you must:

validate ownership details;

provide proof of purchase to an authorised Shingleback employee showing the date of purchase of the Product(s); and



provide a full description of the defect whether material, workmanship or structural integrity and whether it's for a major or a minor component of the Product(s).

(c) Shingleback reserves the right to inspect and test defective part(s) that are the subject of any claim under this Warranty.

(d) The servicing or repair of your Products(s) by third parties that are not authorised by Shingleback will not void your warranties.

However, to the extent that any problem arises due to any third-party servicing or repairs, Shingleback reserves the right to request additional information about the work and servicing performed on your Product(s). Shingleback will not be liable for damages, defect or failure caused by having Product(s) serviced or repaired by third parties that are not authorised by Shingleback.

(e) Shingleback reserve the right to, at their discretion, deny or cancel all or a portion of the reimbursement and/or warranties given under this Warranty, in the event that your present incomplete, insufficient, false and/or fraudulent claims and/or documents in relation to this Warranty.

4.2 To honour a valid claim made under this Warranty, we will either repair or replace the Product(s) within the applicable warranty period free-of-charge or authorise the Product(s) to be replaced or repaired free-ofcharge. Unless required by law, our maximum liability extends to the repair or replacement of the defective Product(s), or at our sole discretion, a full refund up to the maximum purchase price.

4.3 This Warranty does not provide for reimbursement or payment of incidental expenses or consequential damages.

5. Warranty Exclusions

5.1. The scope of this Warranty is expressly limited to items constructed by Shingleback.

5.2. Claims that do not fall under the term "defects from manufacture" will not be covered by this Warranty. Claims that will not be covered include, but are not limited to, claims in relation to:

(a) Product Care - Failure to maintain and care for your Product(s), including the powder coating in accordance with Shingleback recommendations.

Improper maintenance, such as use of incorrect cleaning agents.

(b) Damage - Any defects resulting from an accident, impact, fire, improper repairs or illegal use or malicious or accidental damage to your Product(s) (including damage by a third person).

(c) Instructions - Defects where you have not used the Product(s) in accordance with the operating instructions or design specifications.

(d) Misuse - Any defects resulting from operator negligence, misuse or abuse, loading beyond specified load and capacity, use in off road condition beyond the designed or intended use of the Product(s).

(e) Modifications - Any modifications, dismantling or other alterations that have not been approved by Shingleback. Any defect caused by changes to original equipment and the fitment of non-approved parts or accessories. Product(s) to be replaced or repaired free-ofcharge. Unless required by law, our maximum liability extends to the repair or replacement of the defective Product(s), or at our sole discretion, a full refund up to the maximum purchase price.

4.3 This Warranty does not provide for reimbursement or payment of incidental expenses or consequential damages.

5. Warranty Exclusions

5.1. The scope of this Warranty is expressly limited to items constructed by Shingleback.

5.2. Claims that do not fall under the term "defects from manufacture" will not be covered by this Warranty. Claims that will not be covered include, but are not limited to, claims in relation to:

(a) Product Care - Failure to maintain and care for your Product(s), including the powder coating in accordance with Shingleback recommendations. Improper maintenance, such as use of incorrect cleaning agents.

(b) Damage - Any defects resulting from an accident, impact, fire, improper repairs or illegal use or malicious or accidental damage to your Product(s) (including damage by a third person).

(c) Instructions - Defects where you have not used the Product(s) in accordance with the operating instructions or design specifications.

(d) Misuse - Any defects resulting from operator negligence, misuse or abuse, loading beyond



specified load and capacity, use in off road condition beyond the designed or intended use of the Product(s).

(e) Modifications - Any modifications, dismantling or other alterations that have not been approved by Shingleback. Any defect caused by changes to original equipment and the fitment of non-approved parts or accessories.

(f) Overloading - Any defects resulting from Product(s) being subjected to overloading, for any period of time.

(g) Reporting and repairs – Failure to report warranty defects in a reasonable time and/or have defects repaired in a reasonable time. Failure to have to Product(s) repaired in a reasonable time in accordance with the manufacturer’s recommendations following an accident or other damages within a reasonable time after the defects became known or suspected.

(h) Rust and powder coat - This Warranty does not cover the cosmetic appearance of your Product(s) and excludes deterioration due to rust or the fading of any painted or other types of surfaces.

(i) Consumables – Stickers, bungee cord loops, buttons, handles, plastic caps, Anti-Rattle Clamp or devices.

6. Guarantees under the Australian Consumer Law

6.1. Our goods come with guarantees that cannot be excluded under the Australian Consumer Law.

6.6 This document should not be read as excluding, restricting or modifying your rights and remedies under the ACL.

7. Keeping your details up to date

7.1. The Australian Government requires manufacturers to be able to contact the current product owner if any recall or service campaigns become necessary. Should you change your address or sell your product, please email contact@shinglebackoffroad.com.au or call us on 0494 127 516 between 9.00am and 5:00pm Monday to Friday (AEST) to update your ownership details.

8. Privacy

8.1. By accepting Terms set out in this Warranty, you agree to your personal information being used and disclosed for the purpose of providing warranty services, and for the purpose of

providing information about other products offered by Shingleback and its related companies.

8.2. For further information, please see our privacy policy available on request or at shinglebackoffroad.com.au

9. Laws and Jurisdiction

9.1. These terms and conditions are governed by and construed in accordance with the laws of the State of Victoria.

10. Our Contact Information

For the purpose of this warranty, we can be contacted as follows:

Shingleback Off Road Pty Ltd
 PO Box 475, Beechworth VIC 3747
 Phone number: 0494 127 516
 Email: contact@shinglebackoffroad.com.au



SHINGLEBACK[®]
OFF ROAD



10 YEAR
GUARANTEE

